

Opportunities for process
manufacturing in a circular economy

HØYANGER INDUSTRIAL PARK

A stylized map of Norway in a dark red color, showing the coastline and major cities. A red dot is placed on the western coast, with a white circle and a red dot inside it, indicating the location of Høyanger. The word "HØYANGER" is written in white capital letters next to the dot.

HØYANGER

HØYANGER TOWN

Høyanger is a compact little town, and it is only 1.5 km between Høyanger Industrial Park in the north-east and Leira Industrial Park's factory in the south-west. This industrial town has a population of 2,000 and all the services and amenities you need for a comfortable life.

 Førde Airport
Bringeland – 50km

 Regional capital
Bergen – 160km



HØYANGER INDUSTRIAL PARK

SCHOOL AND SPORTS CAMPUS

CENTRAL HØYANGER
SHOPS AND SERVICES

ISPS PORT

HYDRO ALUMINIUM

LEIRA INDUSTRIAL PARK
FACTORY WITH ARC FUME TECHNOLOGY



OPPORTUNITIES

Høyanger is home to a highly skilled process manufacturing industry and a number of high-performing companies.

Access to qualified labour is good, and the local community has a long-standing tradition of tolerance towards round-the-clock operation and shift work. The town also boasts long-established logistics, maintenance and automation sectors.

Høyanger is able to offer low-cost renewable energy to promising manufacturing projects.

Høyanger's infrastructure, corporate and local culture are ideal for establishing and running new manufacturing operations.

Høyanger has extensive expertise on:

- Lean
- Process manufacturing
- Maintenance
- Lab
- Energy
- HR
- Project management
- Automation
- Health and safety
- Logistics and the natural environment

Høyanger Industrial Park

AN INDUSTRIAL ESTATE WITH GREAT POTENTIAL

A 22,000 m² industrial estate on the outskirts of central Høyanger well suited to a range of different manufacturing and production processes.



Høyanger Industrial Park can offer flexible production facilities, workshops and offices.



Connected to LNG plant

The ISPS port facility 1 km away is run by Hydro, and there are plans for a roll-on/roll-off berth. Crane with 20-tonne capacity

Nearby waste disposal sites: Førde, Kaupanger and Voss

Høyanger Industrial Park **SMELTING AND HOLDING FURNACES FOR METALLURGICAL MANUFACTURING**

Høyanger Industrial Park has two holding furnaces each with a capacity of 7 tonnes and one holding furnace with a capacity of 12 tonnes. There are also two smelting furnaces on site with a capacity of 22 and 32 tonnes respectively.

The LNG powered smelting furnaces can achieve temperatures of up to 1,000 °C. The electrical holding furnaces can achieve temperatures of up to 900 °C.

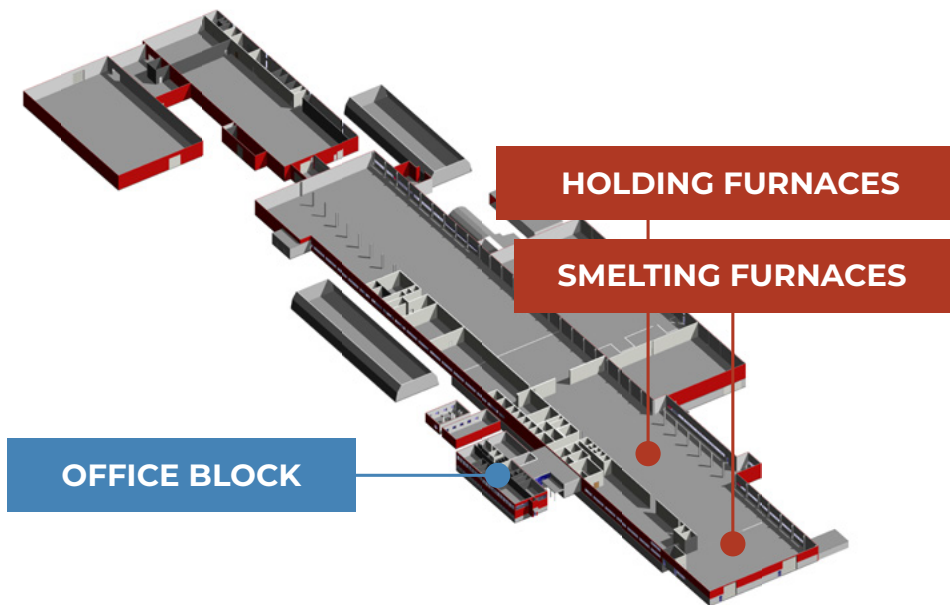

Holding



Smelting

Høyanger Industrial Park

FLEXIBLE PREMISES

The industrial park has premises suitable for a range of different manufacturing and production processes. The park can be partitioned according to the tenants' needs and wishes. There are also offices, warehouses, a canteen and changing room facilities on site.



Høyanger Industrial Park

EXTENSIVE OUTDOOR AREA

The industrial park has extensive outdoor area on three sides of the buildings suitable for storage.

There is scope for expanding into the mountainous terrain to the north.



STORAGE SPACE
NORTH

CAR PARK

STORAGE SPACE
SOUTH-WEST

STORAGE SPACE
WEST

Høyanger Industrial Park **OFFICE AND WORKSHOP BUILDING**

Høyanger Industrial Park also consist of a freestanding building constructed in the year 2000 with an overall area of 4100m² situated 150 meters from the main building.

This smaller building is also well suited for different types of business activities with its office facilities and flexible workshop and production premises.





WELCOME TO HØYANGER

Høyanger was founded on industry. The town has the infrastructure, facilities, expertise and culture needed for industrial development and manufacturing.

It is our ambition to play a proactive role in the process manufacturing industry in the circular economy of the future, and we are looking to make contact with enterprises with similar visions. Robust, forward-looking projects focusing on the optimal use of resources in the industrial value chain will be met with goodwill and interest from both the local community and their political leaders.

Get in touch if you want to learn more about the opportunities that Høyanger has to offer.



**HØYANGER INDUSTRIAL PARK IS AN IDEAL
LOCATION FOR DEVELOPING NEW SUSTAINABLE
PROCESS MANUFACTURING SOLUTIONS**



Petter Sortland
Mayor

Telephone: +47 57 71 15 52

Mobile: +47 91 16 45 46

Email: petter.sortland@hoyanger.kommune.no